



2.7 Dimensioni

2.7 Dimensions

2.7 Abmessungen

Flangia uscita / Output flange / Abtriebsflansch

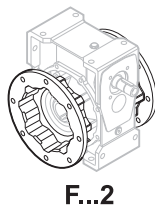
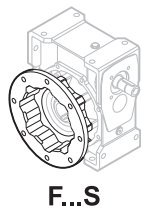
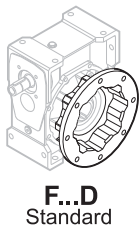
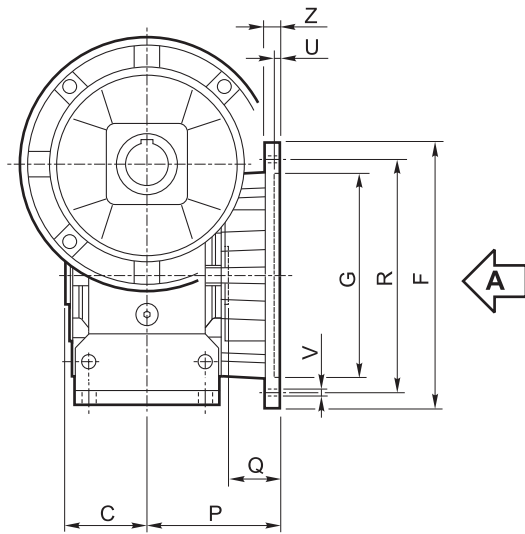

Vista da A / View from A / Ansicht von A

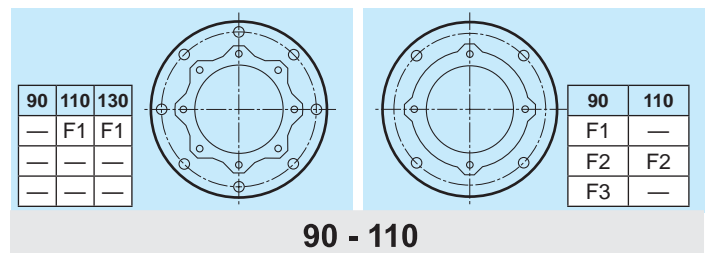
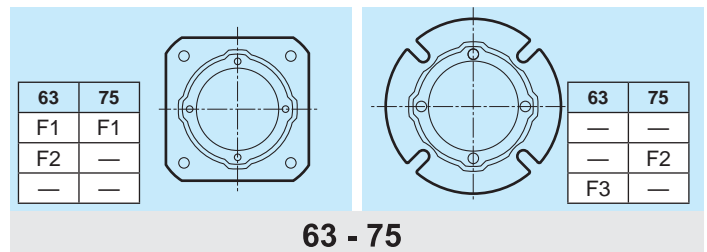
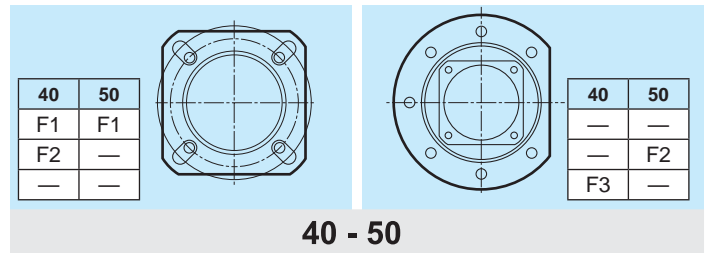
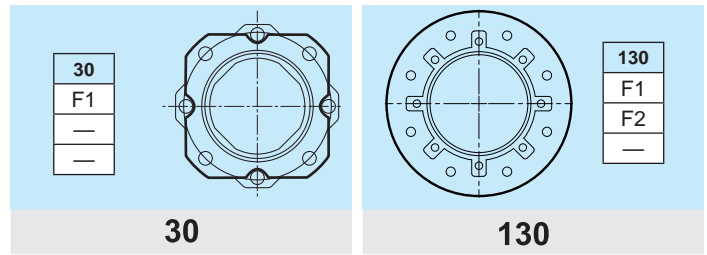

Tipo Type Typ	C	F		G H8	P	Q	R	U	V			Z
											Ø	
30	31.5		66	50	54.5	23	68	4	n° 4		6.5	6
40	39		85	60	67	28	75-90	4	n° 4		9	8
			85	60	97	58	75-90	4	n° 4		9	8
		140	95	80	80	41	115	5		n° 7	9	10
50	46		94	70	90	44	85-100	5	n° 4		11	10
		160		110	89	43	130	5		n° 7	11	11
63	56		142	115	82	26	150	5	n° 4		11	11
			142	115	112	56	150	5	n° 4		11	11
		160		110	80.5	24.5	130	5	n° 4		11	12
75	60		160	130	111	51	165	5	n° 4		13	12
		160		110	90	30	130	6	n° 4		11	13
90	70	200		152	111	41	175	5	n° 4		13	12
		200		152	151	81	175	5	n° 4		13	13
		200		130	110	40	165	6	n° 4		11	11
110	77.5	260		170	131	53.5	230	6		n° 8	13	15
		250		180	150	72.5	215	5	n° 4		15	16
130	85	320		180	140	55	255	7		n° 8 *	16	16
		300		230			265					

* Foratura ruotata di 22.5°

* Drilling turned of 22.5°

* Durchbohrung 22.5° versetzt