

# **trasmissioni**

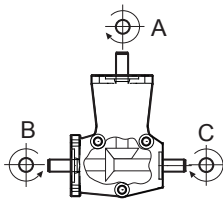

**Serie / Series Dz**



MOD.	DZ		Rapp.	Entrata	Uscita	Modello	Peso
			Ratio	In	Out	Model	Weight
MISURA SIZE	1		1/1	A	B	DZ 10S – 2FAB –	Kg 0.3
			1/1	A	C	DZ 10FS2FAC –	
FLANGE FLANGES	2		1/2	A	B	DZ 12S – 2FAB –	
			1/2	A	C	DZ 12FS2FAC –	
			1/1	A	B – C	DZ 11 – – 2FABC	
			1/2	A	B – C	DZ 13 – – 2FABC	

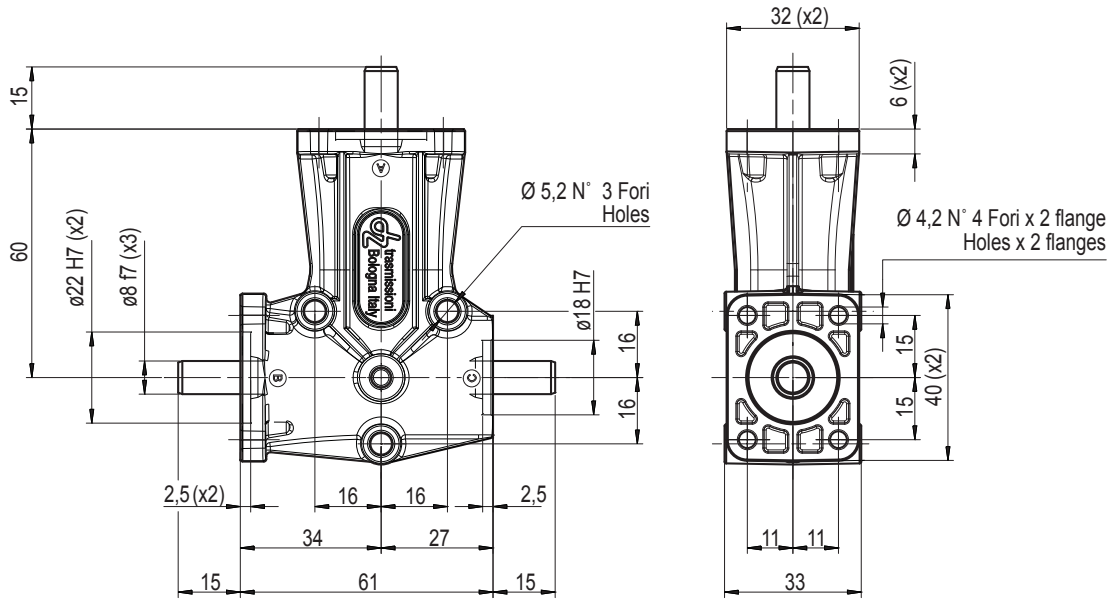

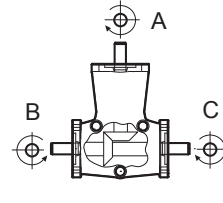
MOD.	DZ		Rapp.	Entrata	Uscita	Modello	Peso
			Ratio	In	Out	Model	Weight
MISURA SIZE	1		1/1	A	B	DZ 10S – 3FAB –	Kg 0.3
			1/1	A	C	DZ 10FS3FAC –	
FLANGE FLANGES	3		1/2	A	B	DZ 12S – 3 FAB –	
			1/2	A	C	DZ 12FS3FAC –	
			1/1	A	B – C	DZ 11 – – 3FABC	
			1/2	A	B – C	DZ 13 – – 3FABC	

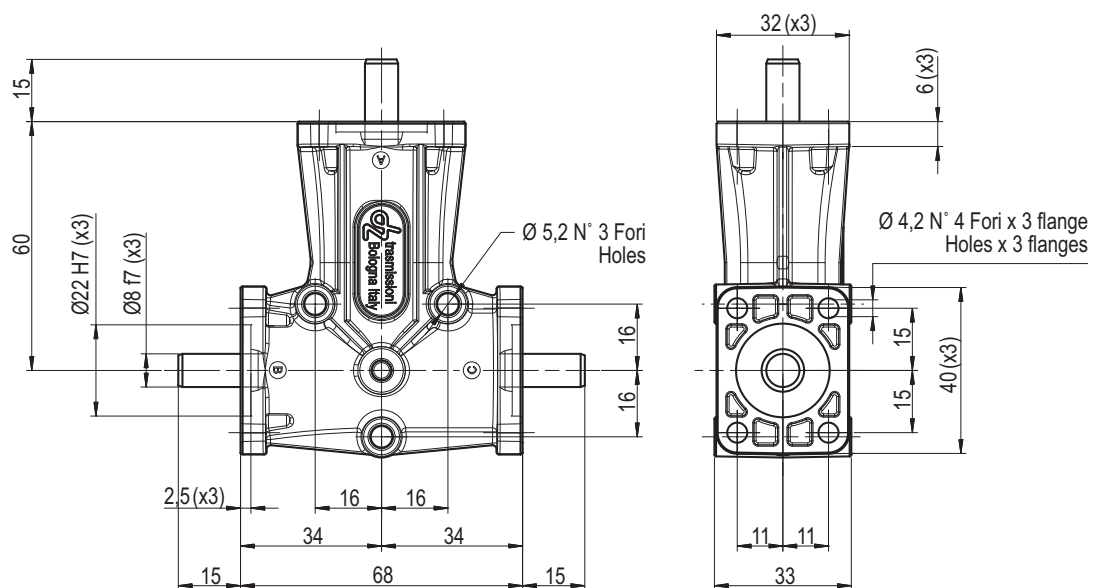



MOD.	DZ	Rapp.	Entrata	Uscita	Modello	Peso
					Model	Weight
MISURA SIZE	2	1/1	A	B	DZ 20S-2FAB-	Kg 1.1
FLANGE FLANGES	2	1/1	A	C	DZ 20FS2FAC-	
		1/2	A	B	DZ 22S-2FAB-	
		1/2	A	C	DZ 22FS2FAC-	
		1/1	A	B - C	DZ 21--2FABC	Kg 1.2
		1/2	A	B - C	DZ 23--2FABC	

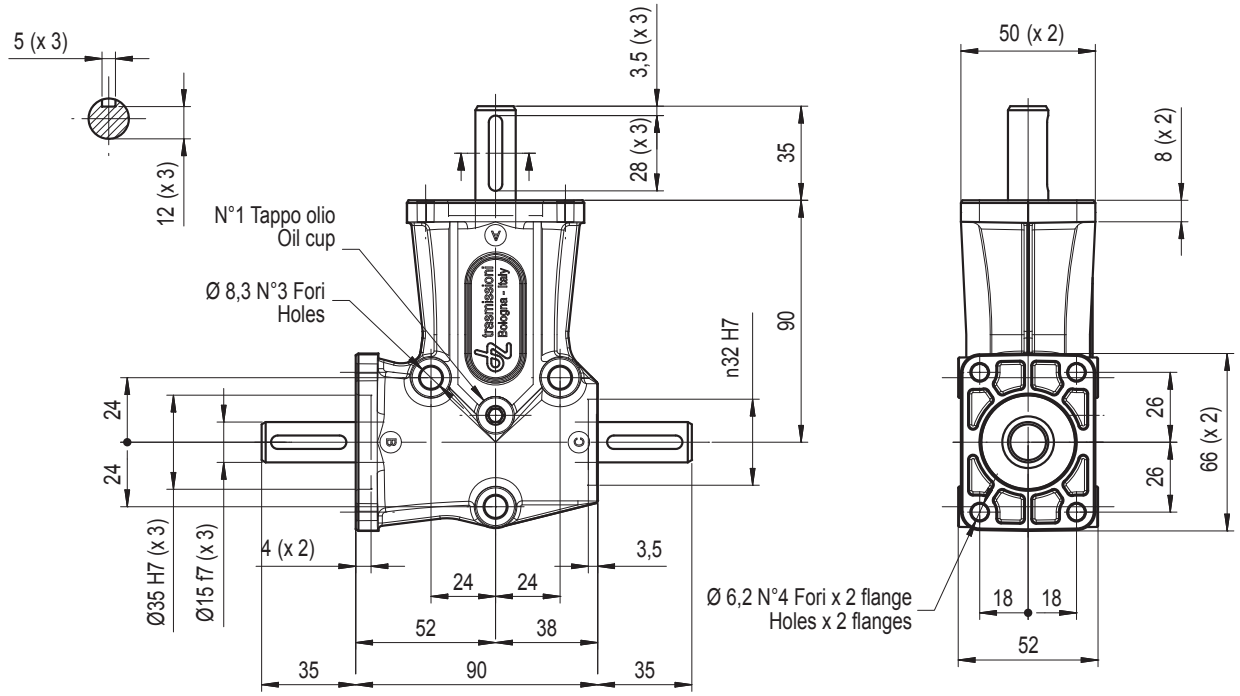
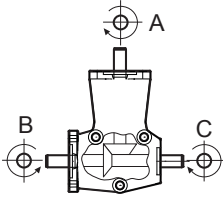

MOD.	DZ	Rapp.	Entrata	Uscita	Modello	Peso
					Model	Weight
MISURA SIZE	2	1/1	A	B	DZ 20S-3FAB-	Kg 1.1
FLANGE FLANGES	3	1/1	A	C	DZ 20FS3FAC-	
		1/2	A	B	DZ 22S-3FAB-	
		1/2	A	C	DZ 22FS3FAC-	
		1/1	A	B - C	DZ 21--3FABC	Kg 1.2
		1/2	A	B - C	DZ 23--3FABC	

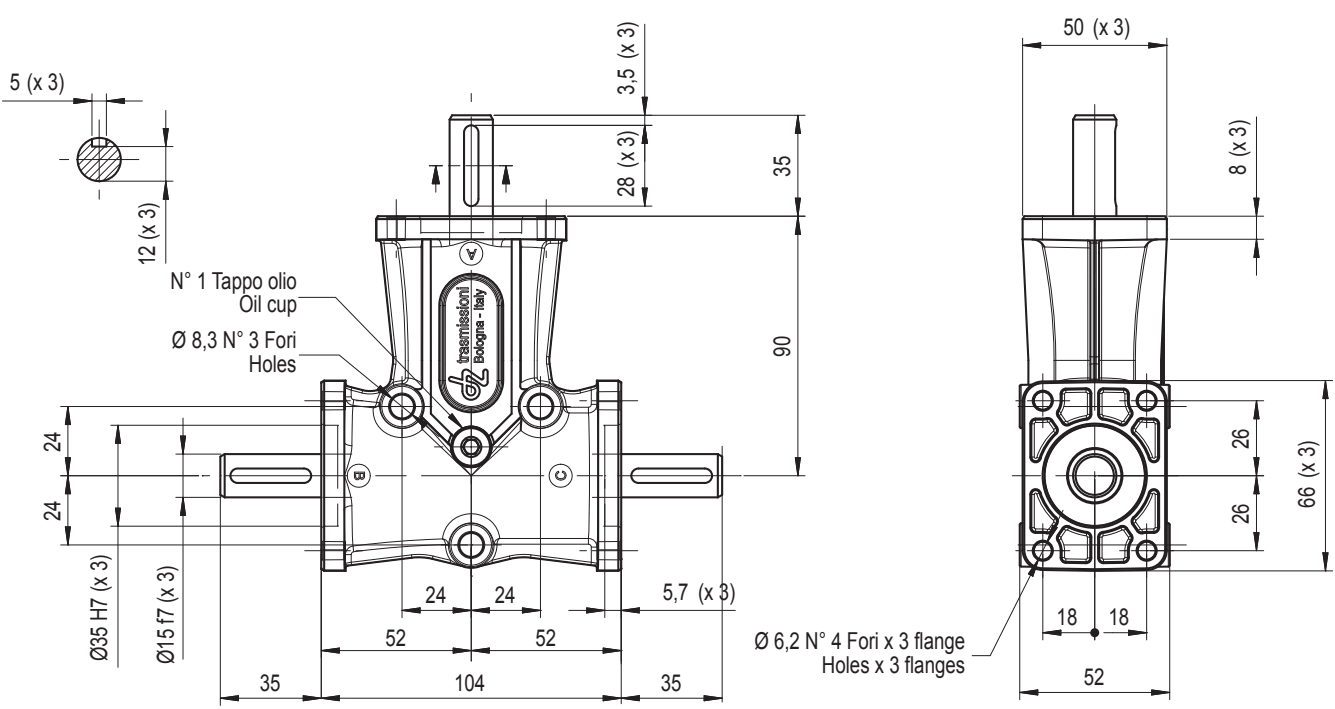
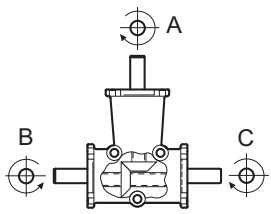



MOD.	<b>DZ</b>		Rapp.	Entrata	Uscita	Modello	Peso		
			Ratio	In	Out	Model	Weight		
MISURA SIZE	<b>3</b>		1/1	A	B-C	DZ 311-3FABC	Kg 3.3		
ALBERO CAVO HOLLOW SHAFT									

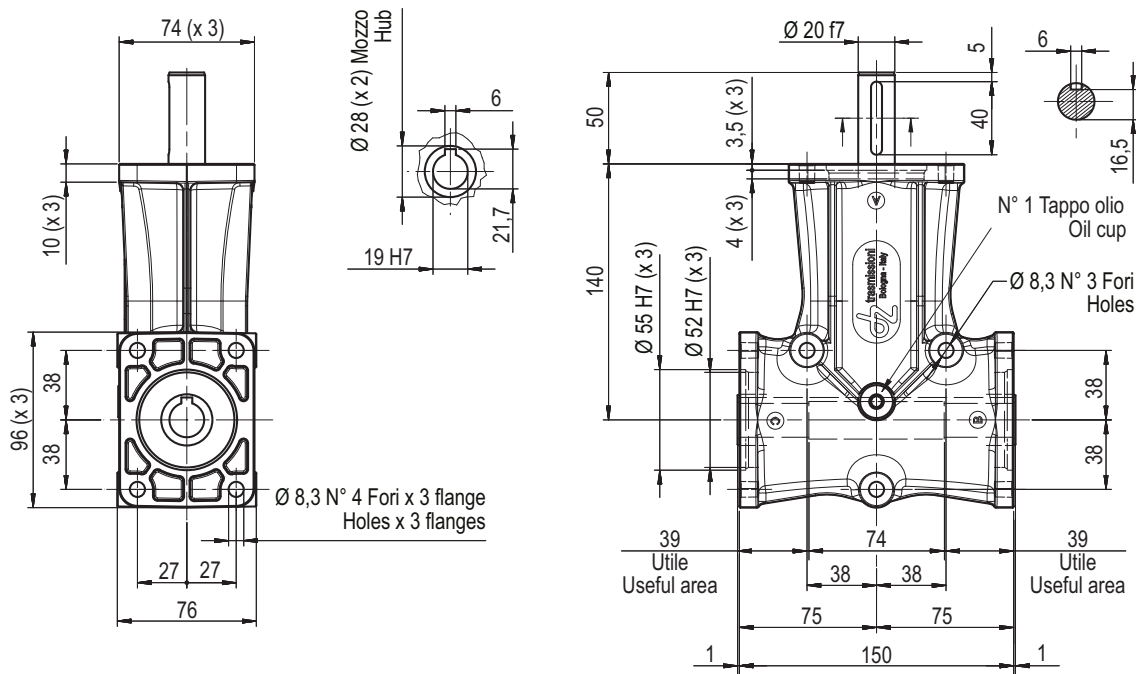

MOD.	<b>DZ</b>		Rapp.	Entrata	Uscita	Modello	Peso	
			Ratio	In	Out	Model	Weight	
MISURA SIZE	<b>3</b>		1/1	A	B	DZ 30S-3FAB-	Kg 3.4	
			1/1	A	C	DZ 30FS3FAC-		
			1/2	A	B	DZ 32S-3FAB-		
			1/2	A	C	DZ 32FS3FAC-	Kg 3.5	
		1/1	A	B - C	DZ 31-3FABC			
		1/2	A	B - C	DZ 33-3FABC			

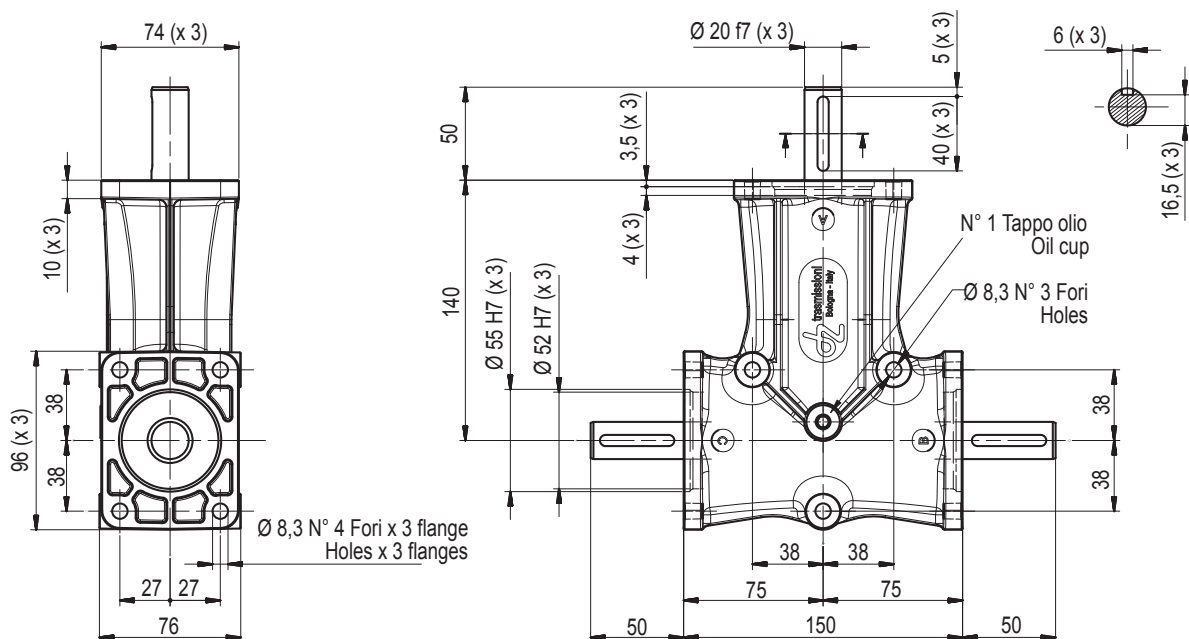



MOD.	DZ	Rapp.	Entrata	Uscita	Modello	Peso
MISURA SIZE	4	Ratio	In	Out	Model	Weight
		1/1	A	B	DZ 40S-3FAB-	Kg 5.5
		1/1	A	C	DZ 40FS3FAC-	
		1/2	A	B	DZ 42S-3FAB-	
		1/2	A	C	DZ 42FS3FAC-	
		1/1	A	B - C	DZ 41--3FABC	Kg 5.8
		1/2	A	B - C	DZ 43--3FABC	

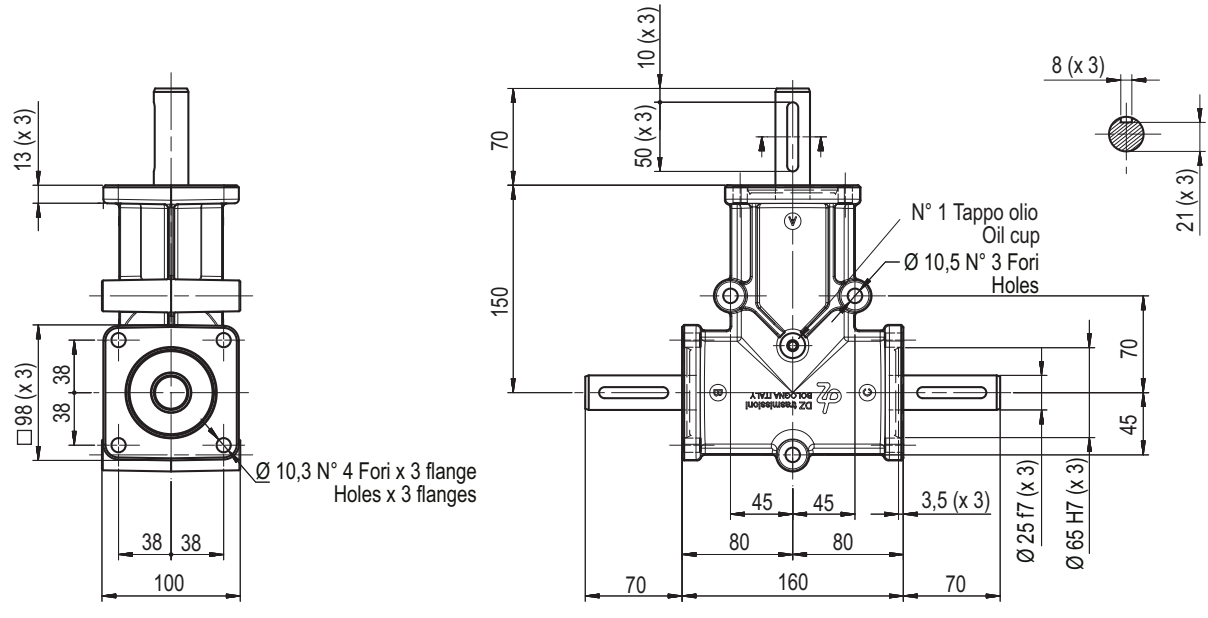
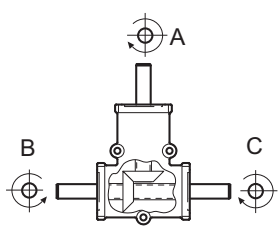

MOD.	DZ	Rapp.	Entrata	Uscita	Modello	Peso
MISURA SIZE	5	Ratio	In	Out	Model	Weight
		1/1	A	B	DZ 50S-3FAB-	Kg 8.1
		1/1	A	C	DZ 50FS3FAC-	
		1/2	A	B	DZ 52S-3FAB-	
		1/2	A	C	DZ 52FS3FAC-	
		1/1	A	B - C	DZ 51--3FABC	Kg 8.8
		1/2	A	B - C	DZ 53--3FABC	

