

#### QUICK SELECTION / Selezione veloce

input speed ( $n_1$ ) = 1400 min<sup>-1</sup>

Output Speed $n_2$ [min <sup>-1</sup> ]	Ratio $i$	Motor power $P_{1M}$ [kW]	Output torque $M_{2M}$ [Nm]	Service factor f.s.	Nominal power $P_{1R}$ [kW]	Nominal torque $M_{2R}$ [Nm]	Available B5 motor flanges		Available B14 motor flanges		Dynamic efficiency <b>RD</b>	Tooth Module  [mm]	Ratios code 
							-A	-B	-O	-P			
							56	63	56	63			
5.6	<b>252</b>	0.12	97	1.1	<b>0.14</b>	<b>109</b>	B		B-C		47	2.1	01
3.9	<b>360</b>	0.12	124	0.9	<b>0.11</b>	<b>109</b>	B		B-C		42	2.1	02
2.6	<b>540</b>	0.12*	109	<0.8	<b>0.08</b>	<b>109</b>	B		B-C		39	2.1	03
1.9	<b>720</b>	0.12*	109	<0.8	<b>0.06</b>	<b>109</b>	B		B-C		36	2.1	04
1.6	<b>860</b>	0.12*	109	<0.8	<b>0.06</b>	<b>109</b>	B		B-C		32	1.8	05
1.2	<b>1200</b>	0.12*	109	<0.8	<b>0.05</b>	<b>109</b>	B		B-C		27	1.3	06
1.0	<b>1440</b>	0.12*	109	<0.8	<b>0.04</b>	<b>109</b>	B		B-C		26	2.1	07
0.8	<b>1720</b>	0.12*	109	<0.8	<b>0.04</b>	<b>109</b>	B		B-C		25	1.8	08
0.6	<b>2400</b>	0.12*	104	<0.8	<b>0.03</b>	<b>104</b>	B		B-C		21	1.3	09

**Motor Flanges Available**  
Flange Motore Disponibili

**B) Supplied with Reduction Bushing**  
Fornito con Bussola di Riduzione

**B) Available on Request without reduction bushing**  
Disponibile a Richiesta senza Bussola di Riduzione



**C) Motor Flange Holes Position**  
Posizione Fori Flangia Motore

\* Power higher than the maximum one which can be supported by the gearbox. Select according to the torque  $M_{2R}$   
Potenza superiore a quella massima sopportabile dal riduttore. Selezionare in base al momento torcente  $M_{2R}$

**EN** Unit 503 is supplied with synthetic oil, providing "long life" lubrication. For mounting position V5-V6 please contact us. See table 1 for lubrication and recommended quantity. In table 2 please see possible radial loads and axial loads on the gearbox.

**I** Il riduttore tipo 503 viene fornito lubrificato a vita con olio sintetico. Per posizioni V5-V6 contattare il ns. servizio tecnico. Vedi tab.1 per oli e quantità consigliati. In tab.2 sono presenti i carichi radiali e assiali applicabili al riduttore.

**D** Für die Lebensdauerschmierung ist das Getriebe der Größe 503 mit synthetischem Öl befüllt. Bei Einbaulage V5 oder V6 bitten wir um Rücksprache. In Tabelle 1 ist die Schmiermenge und das empfohlene Schmiermittel angegeben. In Tabelle 2 sind die zulässigen Radial- und Axialbelastungen des Getriebes aufgeführt.

**F** Le réducteur de type 503 est fourni lubrifié à vie avec de l'huile synthétique. Concernant les positions V5.V6, contactez notre service d'assistance technique. Voir tableau 1 concernant les huiles et les quantités conseillées. Les charges radiales et axiales applicables au réducteur sont précisées dans le tableau 2.

**E** El reductor tamaño 503 se suministra, lubricado de por vida con aceite sintético. Para las posiciones V5 y V6 contactar con nuestro servicio técnico. Ver tabla 1, para cantidades y aceites recomendados. En la tabla 2, se encuentran las cargas radiales y axiales admitidas por el reductor.

**LUBRICATION 503 Oil** **Quantity 0.14/0.03 Lt.**

**0.14 Lt.**      **0.03 Lt.**

<b>AGIP</b> Telium VSF 320	<b>SHELL</b> Omala S4 WE 320
----------------------------	------------------------------

For all details on lubrication and plugs check our website **tab. 1**  
Per maggiori dettagli su lubrificazione e tappi olio vedi il nostro sito web

### RADIAL AND AXIAL LOADS

**Output shaft**  
Albero di uscita

$n_2$ [min <sup>-1</sup> ]	FA [N]	FR [N]
25	480	2500
15	560	2800

**Input shaft**  
albero in entrata

$n_1$ [min <sup>-1</sup> ]	FA [N]	FR [N]
1400	20	100

\*Strong axial loads in the DX direction are not allowed.  
Non sono consentiti forti carichi assiali con direzione DX

tab. 2

3D dimensions on request

**P503FB...** Basic wormbox  
Riduttore base

M. flanges	Kit code	∅F	A
56B5	K030.4.041	120	61.5
63B5	K030.4.042	140	62.5
56B14	K030.4.046	80	61.5
63B14	K030.4.045	90	62.5

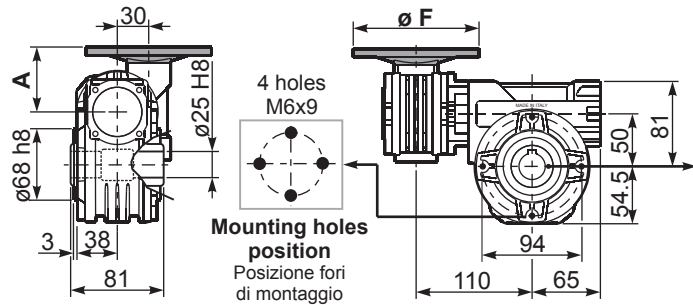

Gearbox weight  
peso riduttore **4.20 kg**

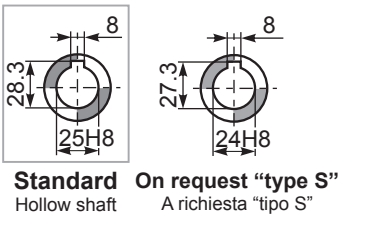

Standard Hollow shaft  
On request "type S"  
A richiesta "tipo S"

**P503PA...** Feet  
Piedini

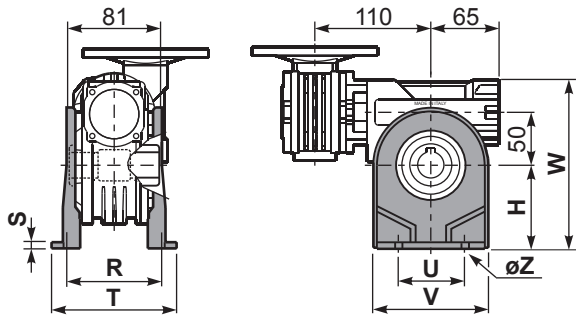

**P503PB...** Feet  
Piedini

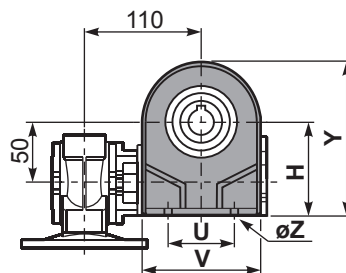

**P503PV...** Feet  
Piedini

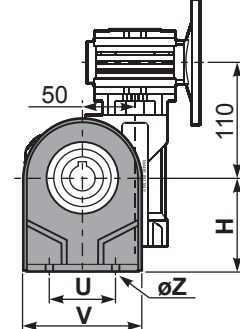

	H	R	S	T	U	V	Y	W	∅Z	kit code
type B	82	98.5	3.5	123	63	113	138.5	163	∅10.5	K050.9.022
type S	85	96	10	114	85	110	139.5	166	∅10	KS050.9.023

**P503FC...** Output flange  
Flangia uscita

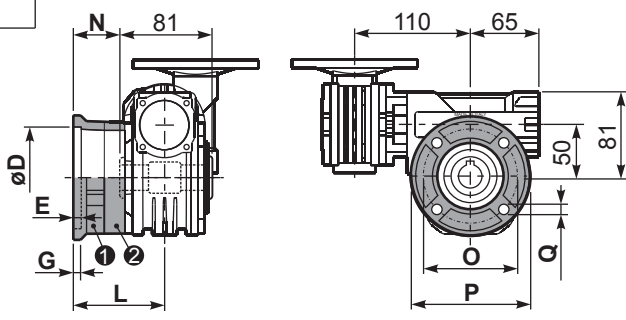

type B	∅D	E	G	L	N	O	P	Q	kit code
FC	70 <sup>+0.20</sup> / <sub>+0.15</sub>	9	12	85	44.5	90	123	10.5	① K050.9.010 ② -
FL	70 <sup>+0.20</sup> / <sub>+0.15</sub>	9	12	114.5	74	90	123	10.5	① K050.9.010 ② K050.0.200
type S	∅D	E	G	L	N	O	P	Q	kit code
F1	110 <sup>+0.20</sup> / <sub>+0.15</sub>	4	11	83.5	43	130	160	10	① KS050.9.012 ② -
F2	70 <sup>+0.20</sup> / <sub>+0.15</sub>	9	12	76.5	36	90	123	10.5	① KS050.9.014 ② -
F3	95 <sup>+0.035</sup> / <sub>0</sub>	4	10	66.5	26	115	140	10	① KS050.9.013 ② -

**P503BR...** Reaction arm  
Braccio di reazione

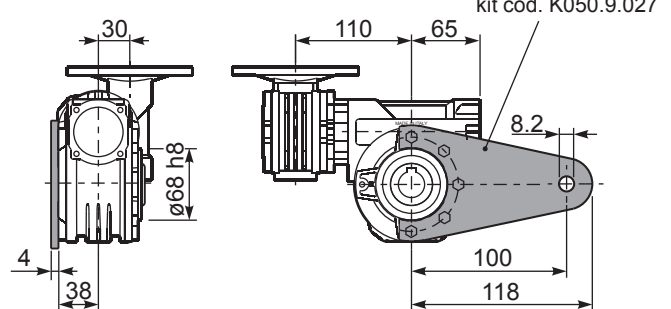

**P503....S...** Single Shaft  
Albero lento semplice

**P503....D...** Double Shaft  
Albero lento bisp.

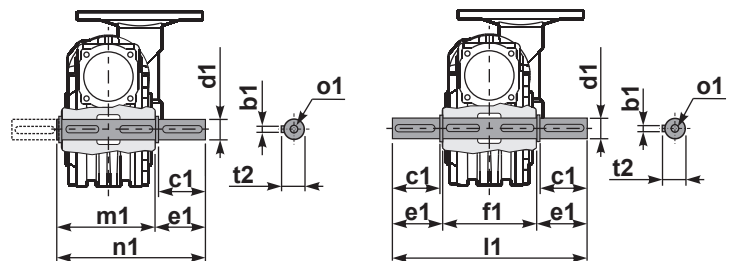

① kit cod. K050.5.028 type B  
kit cod. KS050.5.030 type S  
② kit cod. K050.5.029 type B  
kit cod. KS050.5.031 type S

**R503FB...** Input shaft  
Albero in entrata

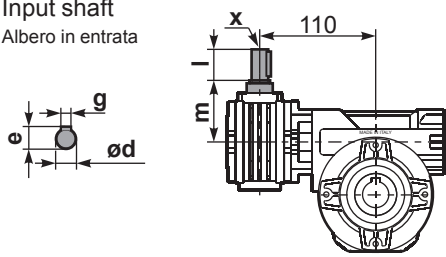

	∅d	e	g	l	m	x	kit code
type B	9 h6	10.2	3	20	58	-	① K030.5.006 PAM63 ② -
type S	-	-	-	-	-	-	① - ② -

	b1	c1	d1	e1	f1	l1	m1	n1	t2	o1
type B	8	52	25 <sup>-0.005</sup> / <sub>-0.020</sub>	59.5	81	200	86.5	146	28	M8x20
type S	8	50	24 <sup>-0.005</sup> / <sub>-0.020</sub>	68.5	81	218	86.5	155	27	M8x20