



QUICK SELECTION / Selezione veloce

input speed (n₁) = 1400 min⁻¹

Output Speed n ₂ [min ⁻¹]	Ratio i	Motor power P _{1M} [kW]	Output torque M _{2M} [Nm]	Service factor f.s.	Nominal power P _{1R} [kW]	Nominal torque M _{2R} [Nm]	Available B5 motor flanges				Available B14 motor flanges			Dynamic efficiency RD	Tooth Module [mm]	Ratios code
							B	C	D	E	Q	R	T			
							63	71	80	90	71	80	90			
22	62.9	0.75	248	1.2	0.87	286					C	C		77	3.10	01
18	78.5	0.75	293	1.0	0.73	286					C	C		73	2.41	02
15	94.2	0.75	333	0.9	0.70	310					C	C		69	2.10	03
11	126	0.55	297	1.0	0.55	296	B				C	C		63	1.53	04
9	157	0.37	230	1.1	0.41	252	B				C	C		58	1.23	05
8	185	0.37	257	1.2	0.43	296	B				C	C		55	3.10	06
6	231	0.25	193	1.5	0.38	296	B				C	C		49	2.41	07
5	277	0.25	222	1.3	0.33	296	B				C	C		47	2.10	08
4	378	0.18	200	1.5	0.27	296	B				C	C		43	2.10	09

A) Motor Flanges Available
Flange Motore Disponibili

B) Supplied with Reduction Bushing
Fornito con Bussola di Riduzione

B) Available on Request without reduction bushing
Disponibile a Richiesta senza Bussola di Riduzione

C) Motor Flange Holes Position
Posizione Fori Flangia Motore

* Power higher than the maximum one which can be supported by the gearbox. Select according to the torque M_{2R}
Potenza superiore a quella massima sopportabile dal riduttore. Selezionare in base al momento torcente M_{2R}

EN Unit P7Q is supplied with synthetic oil, providing "long life" lubrication. For mounting position V5-V6 please contact us. See table 1 for lubrication and recommended quantity. In table 2 please see possible radial loads and axial loads on the gearbox.

I Il riduttore tipo P7Q viene fornito lubrificato a vita con olio sintetico. Per posizioni V5-V6 contattare il ns. servizio tecnico. Vedi tab.1 per oli e quantità consigliati. In tab.2 sono presenti i carichi radiali e assiali applicabili al riduttore.

D Für die Lebensdauerschmierung ist das Getriebe der Größe P7Q mit synthetischem Öl befüllt. Bei Einbaulage V5 oder V6 bitten wir um Rücksprache. In Tabelle 1 ist die Schmiermenge und das empfohlene Schmiermittel angegeben. In Tabelle 2 sind die zulässigen Radial- und Axialbelastungen des Getriebes aufgeführt.

F Le réducteur de type P7Q est fourni lubrifié à vie avec de l'huile synthétique. Concernant les positions V5.V6, contactez notre service d'assistance technique. Voir tableau 1 concernant les huiles et les quantités conseillées. Les charges radiales et axiales applicables au réducteur sont précisées dans le tableau 2.

E El reductor tamaño P7Q se suministra, lubricado de por vida con aceite sintético. Para las posiciones V5 y V6 contactar con nuestro servicio técnico. Ver tabla 1, para cantidades y aceites recomendados. En la tabla 2, se encuentran las cargas radiales y axiales admitidas por el reductor.

LUBRICATION P7Q Oil

For B3-V5-V6 separate lubrication for A (0.40 l) B (0.14 l), for B6-B7-B8 common lubrication 0.65 l (A + B).

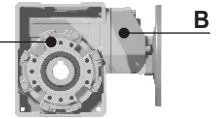

AGIP Telium VSF 320

SHELL Omala S4 WE 320

For all details on lubrication and plugs check our website **tab. 1**
Per maggiori dettagli su lubrificazione e tappi olio vedi il nostro sito web

RADIAL AND AXIAL LOADS

Output shaft

Albero di uscita

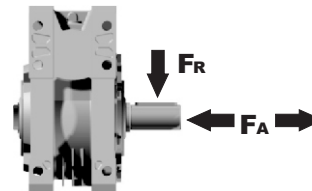

n ₂ [min ⁻¹]	FA [N]	FR [N]
75	620	3100
50	720	3600
25	880	4400
15-6	1000	5000

Input shaft

albero in entrata

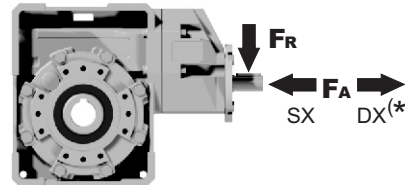

n [min ⁻¹]	FA [N]	FR [N]
1400	108	540

*Strong axial loads in the DX direction are not allowed.
Non sono consentiti forti carichi assiali con direzione DX

tab. 2

PP7Q**FB**... Basic wormbox
Riduttore base

Gearbox weight
peso riduttore **9.90 kg**

M. flanges	Kit code	øF	A
63B5	K063.4.041	140	192.7
71B5	K063.4.042	160	190.7
80/90B5	K063.4.043	200	192.7
71B14	K063.4.047	105	190.7
80B14	K063.4.046	120	192.7
90B14	K063.4.041	140	192.7

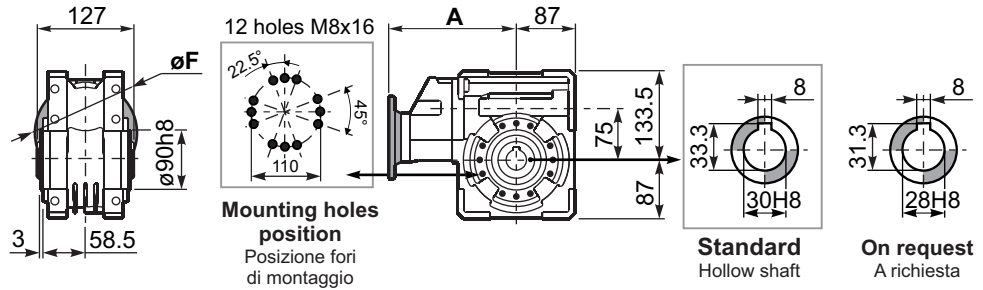

PP7Q**FC**... Square flange
Flangia quadrata

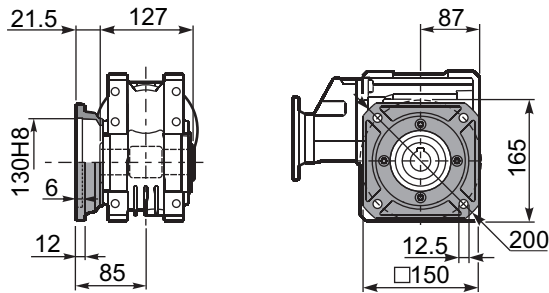

PP7Q**FL**... Square flange
Flangia quadrata

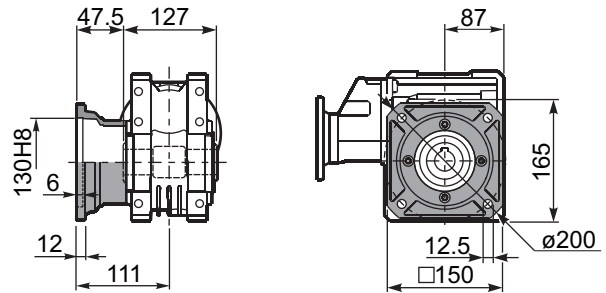

PP7Q**FB**... Feet
Piedini

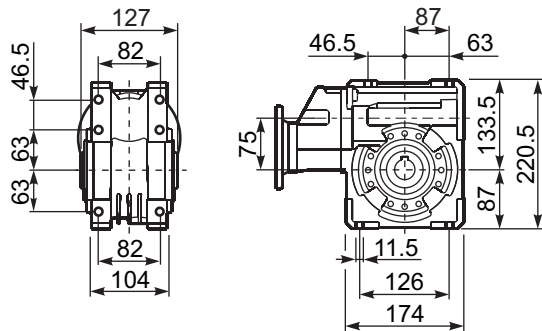

PP7Q**BR**... Reaction arm
Braccio di reazione

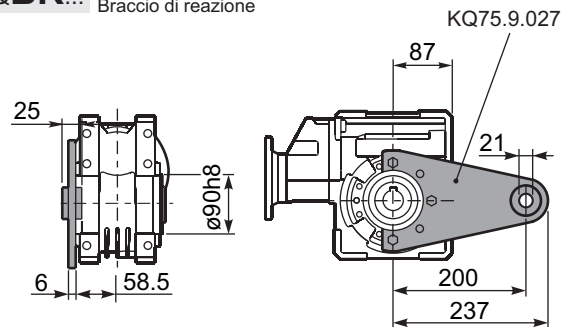

RP7Q**FB**... Input shaft
Albero in entrata

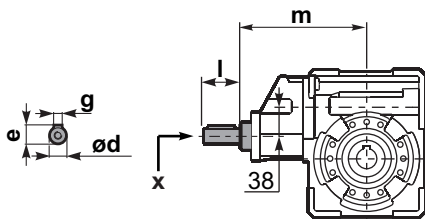

PP7Q....**S**... Single Shaft
Albero lento semplice

PP7Q....**D**... Double Shaft
Albero lento bisp.

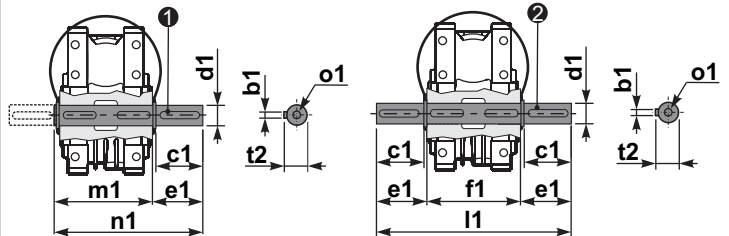

① kit cod. KQ75.5.028 Standard
kit cod. KQ75.5.026 On request

② kit cod. KQ75.5.029 Standard
kit cod. KQ75.5.027 On request

	ød	e	g	l	m	x	
type B	19 h6	21.5	6	35	185.5	M6x16	C40.5.062
type S	-	-	-	-	-	-	

	b1	c1	d1	e1	f1	l1	m1	n1	t2	o1
Standard	8	60	30 ^{-0.005} _{-0.020}	65	127	255	134	199	33	M8x20
On request	8	50	28 ^{-0.005} _{-0.020}	65	127	255	134	199	31	M8x20