

ZR 25

Technical data

Type	i	2800 (min1)				1400 (min1)				900 (min1)				700 (min1)				RD	Kg
		Max.*		Norm.		Max.*		Norm.		Max.*		Norm.		Max.*		Norm.			
		T2m* (Nm)	P1m* (kW)	T2n (Nm)	P1n (kW)	T2m* (Nm)	P1m* (kW)	T2n (Nm)	P1n (kW)	T2m* (Nm)	P1m* (kW)	T2n (Nm)	P1n (kW)	T2m* (Nm)	P1m* (kW)	T2n (Nm)	P1n (kW)		
ZR25	1	33	11	18	5,5	42	6,5	36,1	5,5	46	5,1	30	3,0	53	3,5	30	2,2	0,97	5,7
	2	30	5	14,6	2,2	29,5	4,5	29,6	2,2	33	3,6	30	1,5	37	2,5	30	1,1	0,97	

Important! * The maximum permissible values are indicated, for a quiet operating mode, with safety clutches and a soft start.

Dimensions

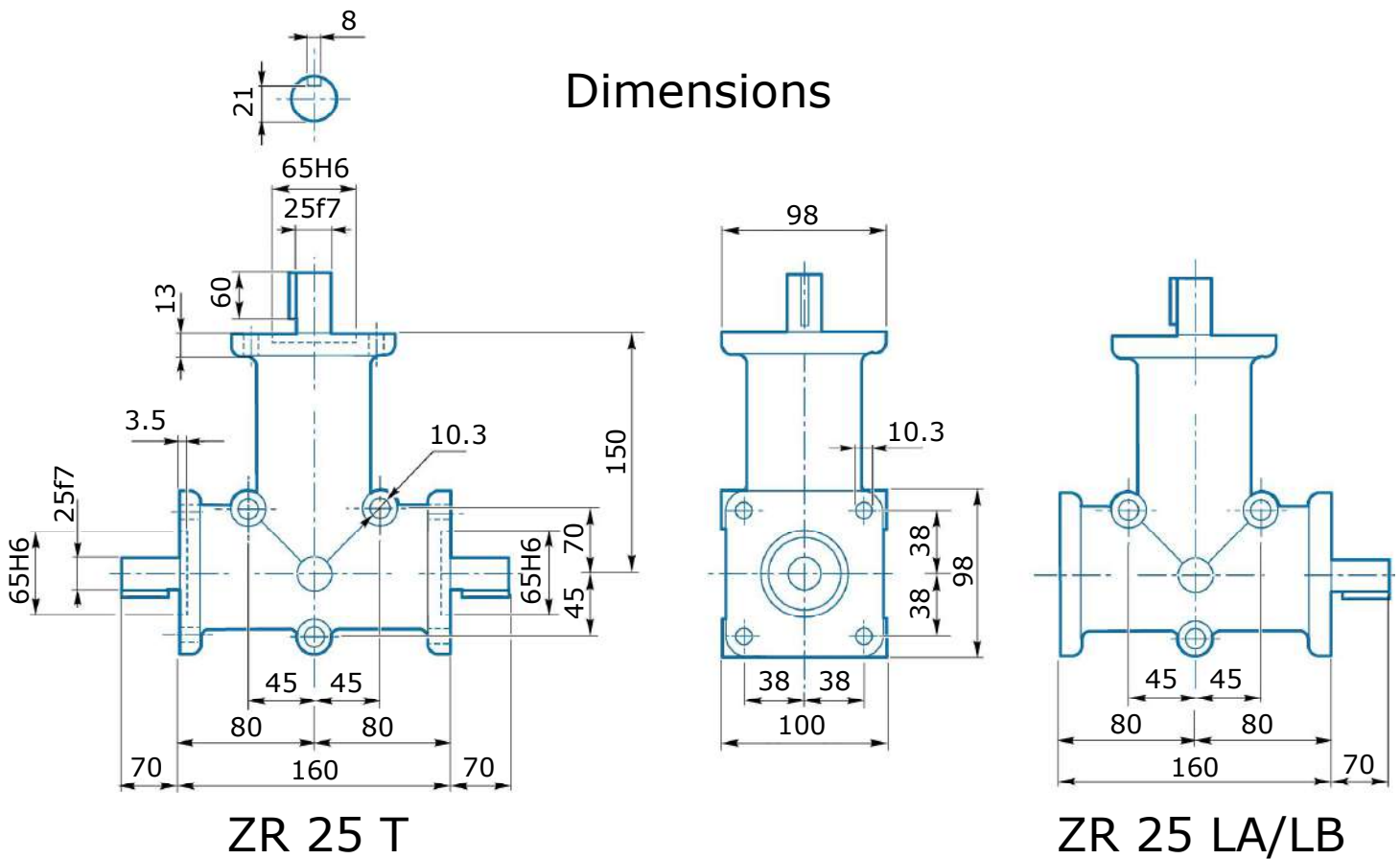

Shafts position and direction of rotation

