

ZR 9

Technical data

Type	i	2800 (min1)				1400 (min1)				900 (min1)				700 (min1)				RD	Kg
		Max.*		Norm.		Max.*		Norm.		Max.*		Norm.		Max.*		Norm.			
		T2m* (Nm)	P1m* (kW)	T2n (Nm)	P1n (kW)	T2m* (Nm)	P1m* (kW)	T2n (Nm)	P1n (kW)	T2m* (Nm)	P1m* (kW)	T2n (Nm)	P1n (kW)	T2m* (Nm)	P1m* (kW)	T2n (Nm)	P1n (kW)		
ZR9	1	3,0	0,82	1,3	0,37	3,0	0,45	1,3	0,18	3,0	0,32	2,0	0,18	2,9	0,19	1,0	0,06	0,97	0,55
	2	2,0	0,27	0,8	0,12	2,0	0,15	1,3	0,09	2,0	0,11	2,0	0,09	1,1	0,07	1,0	0,03	0,97	

Important! * The maximum permissible values are indicated, for a quiet operating mode, with safety clutches and a soft start.

Dimensions

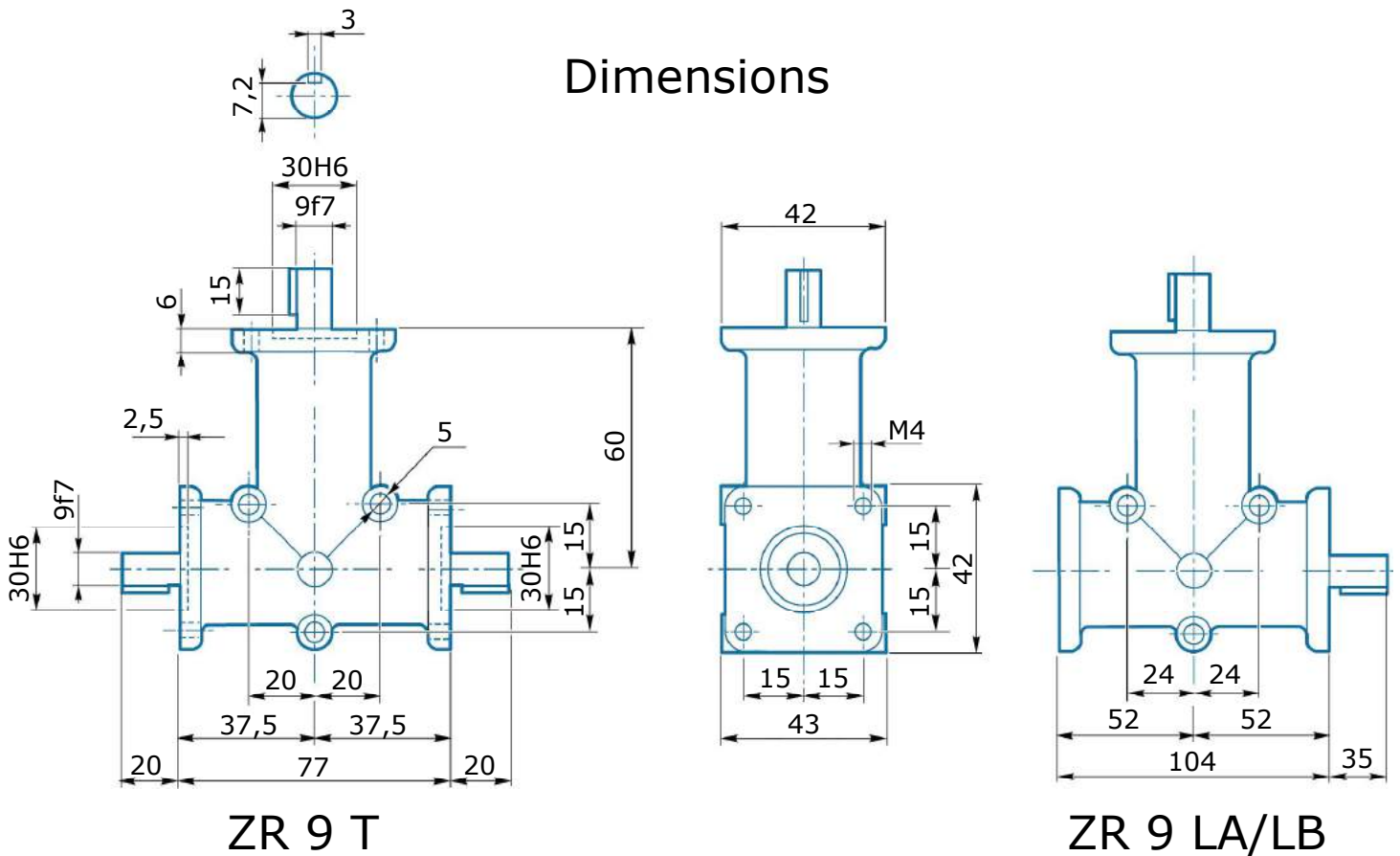

Shafts position and direction of rotation

