

Series <b>CHQ</b> Series	Diametri prese di forza PTO diameters			Dimensioni forma costruttiva Tipo 1 Type 1 constructive form dimensions																	
Taglia Size G1	A Ø h7	B - C Ø h7	G2 Ø f7	G3	G4	G5	L1	L2	L3	L9	L4	L5	L6	L7	L8	L10	L11	H1	H2	P1	P2
<b>54</b>	11	18	53	8.5	10	52.8	44	23	1.5	72	95	27	122	35	74	144	144	4x4x20	6x6x30	M4x10	M4x12
	R							18			35		107					134			
<b>86</b>	16	24	84	15	10	59	70	30	2	84	114	43	157	50	120	220	220	5x5x25	8x7x40	M6x12	M8x20
	R							24			50		134					177			
<b>110</b>	20	26	100	15	13	68	90	40	2	110	150	55	205	55	144	254	254	6x6x35	8x7x45	M8x20	M10x25
	R							26			55		165					220			
<b>134</b>	24	32	122	18	15	80	114	50	2	132	182	67	249	65	174	304	304	8x7x45	10x8x55	M8x20	M10x25
	R							32			65		197					264			
<b>166</b>	32	45	156	21	16	107	144	65	2	152	217	83	300	90	212	392	392	10x8x60	14x9x80	M10x25	M12x30
	R							45			90		242					325			
<b>200</b>	42	55	185	23	16	120	174	85	2	182	267	100	367	110	250	470	470	12x8x80	16x10x100	M10x25	M14x35
	R							55			110		292					392			
<b>250</b>	55	70	230	22	18	152	216	100	3	218	318	125	443	140	300	580	580	16x10x90	20x12x120	M12x25	M16x40
	R							70			140		358					483			
<b>350</b>	65	85	345	30	15	240	320	120	5	330	450	175	625	170	420	760	760	18x11x110	22x14x160	M12x25	M20x60
	R							85			170		500					675			

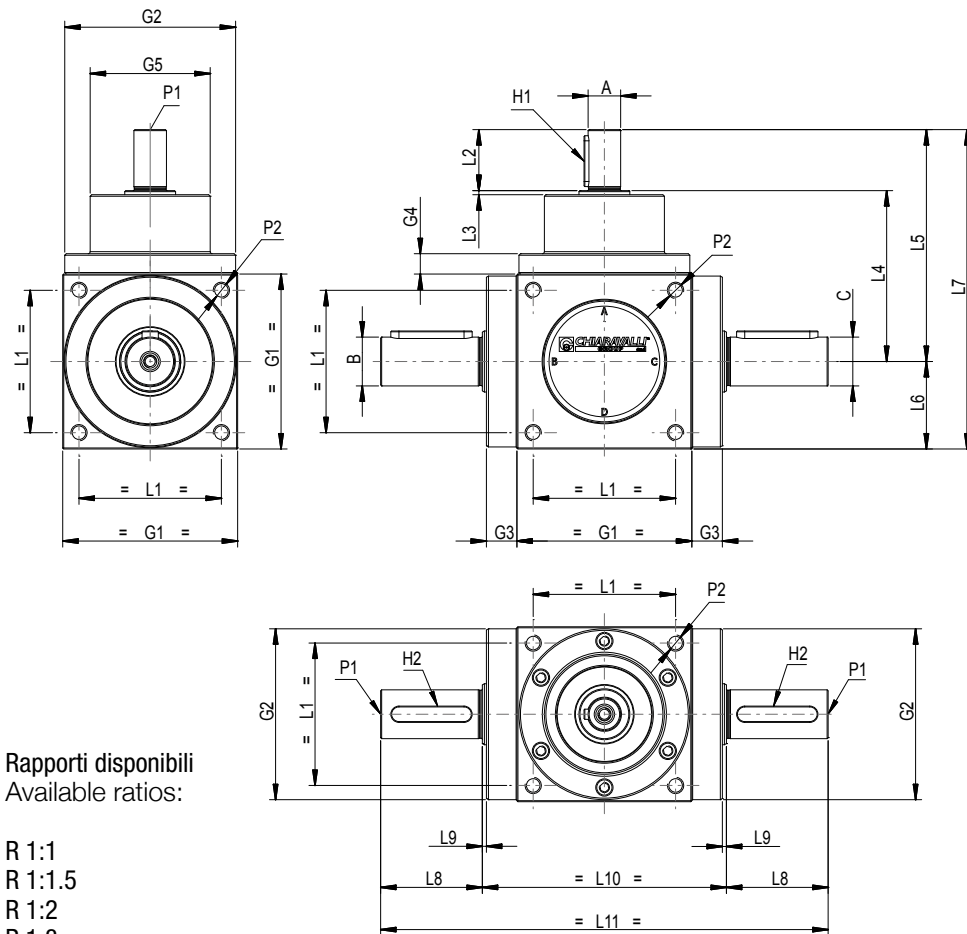

Rapporti disponibili  
Available ratios:

- R 1:1
- R 1:1.5
- R 1:2
- R 1:3
- R 1:4

N.B. Il diametro delle prese di forza "B" e "C" è sempre uguale per taglia.  
Per esigenze diverse consultare l'Uff. Tecnico.

NOTE: The diameter of PTO "B" and "C" is the same for size.  
For any further information please contact our Technical Dept.



Rotazioni forma costruttiva TIPO 1  
TYPE 1 constructive form revolutions