

Serie <b>CHQ</b> Series	Diametri prese di forza PTO diameters		Dimensioni forma costruttiva Tipo 7 Type 7 constructive form dimensions																		
	Taglia Size G1	A - D Ø h7	B Ø h7	G2 Ø f7	G3	G4	G5	L1	L2	L3	L9	L4	L5	L6	L7	L8	L10	L11	H1	H2	P1
<b>54</b>		11	18	53	8.5	10	52.8	44	23	1.5	72	95	27	190	35	37	107.5	4x4x20	6x6x30	M4x10	M4x12
	R	18							35			107		214							
<b>86</b>		16	24	84	15	10	59	70	30	2	84	114	43	228	50	60	168	5x5x25	8x7x40	M6x12	M8x20
	R	24							50			134		268							
<b>110</b>		20	26	100	15	13	68	90	40	2	110	150	55	300	55	72	197	6x6x35	8x7x45	M8x20	M10x25
	R	26							55			165		230							
<b>134</b>		24	32	122	18	15	80	114	50	2	132	182	67	364	65	87	237	8x7x45	10x8x55	M8x20	M10x25
	R	32							65			197		394							
<b>166</b>		32	45	156	21	16	107	144	65	2	152	217	83	434	90	106	300	10x8x60	14x9x80	M10x25	M12x30
	R	45							90			242		484							
<b>200</b>		42	55	185	23	16	120	174	85	2	182	267	100	534	110	125	358	12x8x80	16x10x100	M10x25	M14x35
	R	55							110			292		584							
<b>250</b>		55	70	230	22	18	152	216	100	3	218	318	125	636	140	150	437	16x10x90	20x12x120	M12x25	M16x40
	R	70							140			358		716							
<b>350</b>		65	85	345	30	15	240	320	120	5	330	450	175	900	170	210	585	18x11x110	22x14x160	M12x25	M20x60
	R	85							170			500		1000							

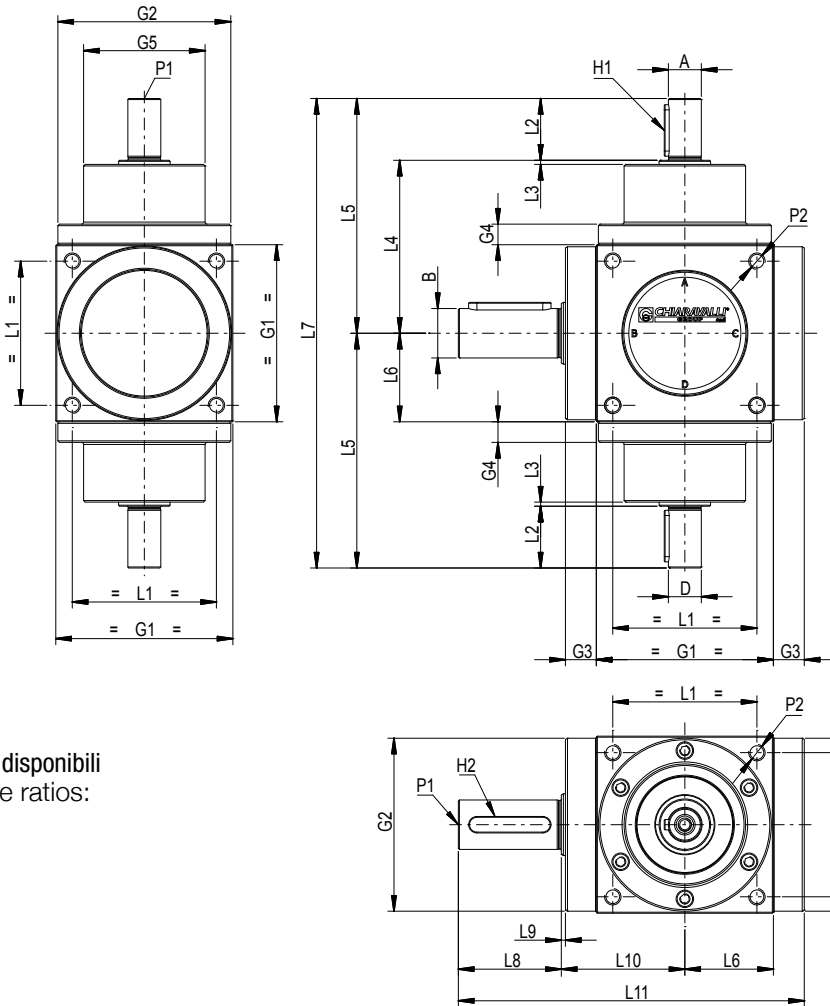

Rapporti disponibili  
Available ratios:

- R 1:1
- R 1:1.5
- R 1:2
- R 1:3
- R 1:4

N.B. Il diametro delle prese di forza "A" e "D" è sempre uguale per taglia.  
Per esigenze diverse consultare l'Uff. Tecnico.

NOTE: The diameter of PTO "A" and "D" is the same for size.  
For any further information please contact our Technical Dept.



Rotazioni forma costruttiva TIPO 7  
TYPE 7 constructive form revolutions