

Serie CHQ Series	Flangia Flange	Diametri prese di forza PTO diameters			Dimensioni Flange PAM PAM Flanges dimensions									
		A Ø h7	C Ø H7	G6	G7	G8	L6	L12	H5	H6	H7	H8	H9	P3
86	56 B5	9	24	120	100	80	43	90	10.4	3	23	4	11	M6
	63 B5	11		140	115	95			12.8	4	23	4	11	M8
	71 B5	14		160	130	110			16.3	5	30	4	11	M8
	71 B14	14		105	85	70			16.3	5	30	4	10	7
	80 B5	19		200	165	130			21.8	6	40	5	11	M10
	80 B14	19		120	100	80			21.8	6	40	5	11	7
110	63 B5	11	26	140	115	95	55	105	12.8	4	23	4	11	M8
	71 B5	14		160	130	110			16.3	5	30	4	11	M8
	71 B14	14		105	85	70			16.3	5	30	4	11	7
	80 B5	19		200	165	130			21.8	6	40	5	11	M10
	80 B14	19		120	100	80			21.8	6	40	5	11	7
	90 B5	24		160	130	110			21.8	6	40	5	11	7
134	71 B5	14	32	160	130	110	67	125	16.3	5	30	4	13	M8
	80 B5	19		200	165	130			21.8	6	40	5	13	M10
	80 B14	19		120	100	80			21.8	6	40	5	13	7
	90 B5	24		200	165	130			27.3	8	50	5	13	M10
	90 B14	24		140	115	95			27.3	8	50	5	13	9
	100-112 B5	28		250	215	180			31.3	8	60	5	13	M12
166	100-112 B14	28	45	160	130	110	83	160	31.3	8	60	5	13	9
	71 B5	14		160	130	110			16.3	5	30	4	15	M8
	80 B5	19		200	165	130			21.8	6	40	5	15	M10
	90 B5	24		200	165	130			27.3	8	50	5	15	M10
	100-112 B5	28		250	215	180			31.3	8	60	5	15	M12
	100-112 B14	28		160	130	110			31.3	8	60	5	15	9
200	90 B5	24	55	200	165	130	100	220	27.3	8	50	5	23	M10
	100-112 B5	28		250	215	180			31.3	8	60	5	23	M12
	132 B5	38		300	265	230			41.3	10	80	6	23	M12
	132 B14	38		200	165	130			41.3	10	80	6	23	11
250	132 B5	38	70	300	265	230	125	250	41.3	10	80	6	25	M12
	132 B14	38		200	165	130			41.3	10	80	6	25	11
	160 B5	42		350	300	250			45.8	12	110	6	25	M16

Per tutte le dimensioni non quotate fare riferimento alle dimensioni dello schema Tipo 3.
 For all non-quoted dimensions, please refer to those of the Type 3 table.

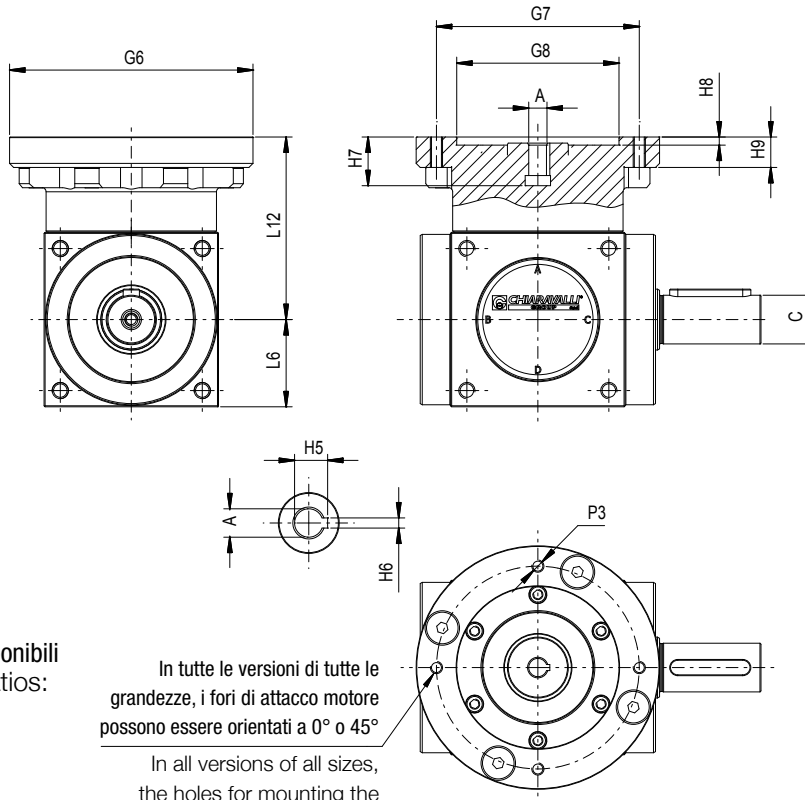

Rapporti disponibili
 Available ratios:

- R 1:1
- R 1:1.5
- R 1:2
- R 1:3
- R 1:4

In tutte le versioni di tutte le grandezze, i fori di attacco motore possono essere orientati a 0° o 45°
 In all versions of all sizes, the holes for mounting the motors can be oriented at 0° or 45°



Rotazioni forma costruttiva TIPO 13
 TYPE 13 constructive form revolutions