

Serie CHQ Series	Diametri prese di forza PTO diameters		Dimensioni forma costruttiva Tipo 26 Type 26 constructive form dimensions																
	Taglia Size G1	A Ø h7	B Ø h7	G2 Ø f 7	G3	G4	G5	L1	L2	L3 L9	L4 L10	L5	L6	L7	L8	L11	H1	H2	P1
54	11	18	53	8.5	10	52.8	44	35	1.5	72	107	27	134	35	142.5	4x420	6x6x30	M4x10	M4x12
86	16	24	84	15	10	59	70	50	2	84	134	43	177	50	172	5x5x25	8x7x40	M6x12	M8x20
110	20	26	100	15	13	68	90	55	2	110	165	55	220	55	220	6x6x35	8x7x45	M8x20	M10x25
134	24	32	122	18	15	80	114	65	2	132	197	67	264	65	267	8x7x45	10x8x55	M8x20	M10x25
166	32	45	156	21	16	107	144	90	2	152	242	83	325	90	321	10x8x60	14x9x80	M10x25	M12x30
200	42	55	185	23	16	120	174	110	2	182	292	100	392	110	390	12x8x80	16x10x100	M10x25	M14x35
250	55	70	230	22	18	152	216	140	3	218	358	125	483	140	465	16x10x90	20x12x120	M12x25	M16x40
350	65	85	345	30	15	240	320	170	5	330	500	175	675	170	655	18x11x110	22x14x160	M12x25	M20x60

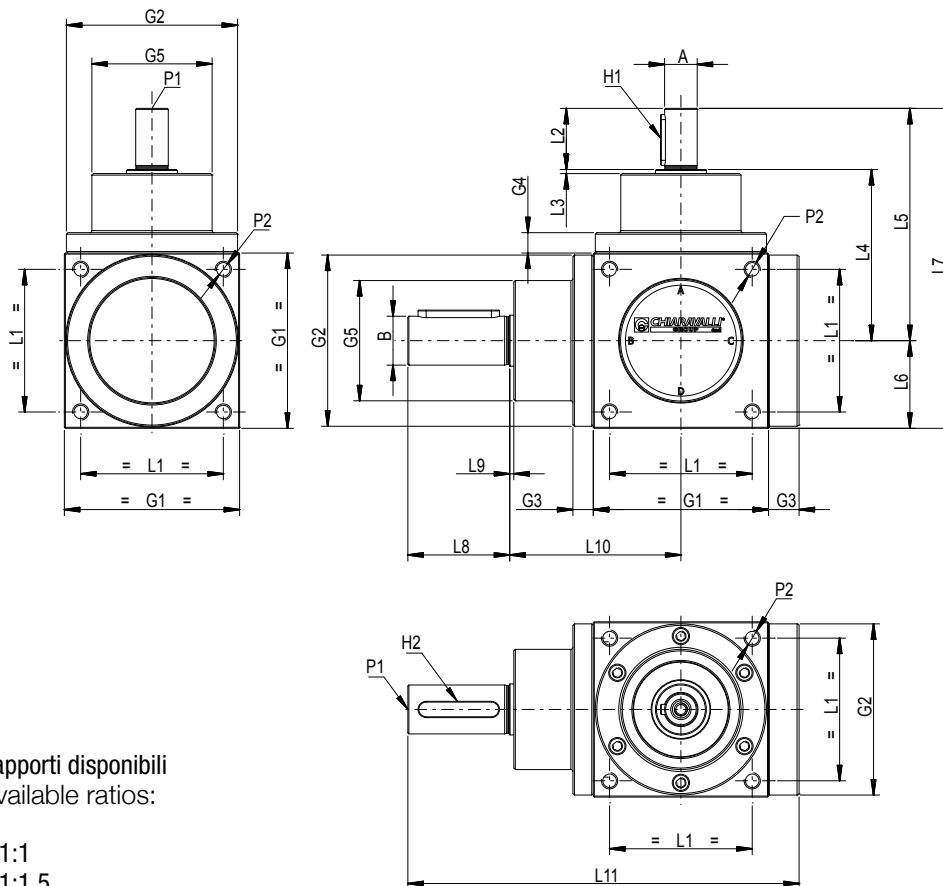

Rapporti disponibili
Available ratios:

- R 1:1
- R 1:1.5
- R 1:2
- R 1:3
- R 1:4



Rotazioni forma costruttiva TIPO 26
TYPE 26 constructive form revolutions