

QUICK SELECTION / Selezione veloce

input speed (n_1) = 1400 min⁻¹

Output Speed n_2 [min ⁻¹]	Ratio i	Motor power P_{1M} [kW]	Output torque M_{2M} [Nm]	Service factor f.s.	Nominal power P_{1R} [kW]	Nominal torque M_{2R} [Nm]	Available B5 motor flanges			Available B14 motor flanges				Dynamic efficiency RD	Tooth Module [mm]	 Ratios code
							-B	-C	-D	-O	-P	-Q	-R			
							63	71	80	56	63	71	80			
6.7	210	0.75	591	1.5	1.1	863	B	B			B-C	B		55	5.6	01
4.7	300	0.75	752	1.3	0.97	978	B	B			B-C	B		49	5.6	02
3.3	420	0.55	741	1.3	0.73	978	B	B			B-C	B		47	5.6	03
2.6	540	0.55	851	1.1	0.63	978	B	B			B-C	B		42	5.6	04
1.8	780	0.37	748	1.3	0.48	978	B	B			B-C	B		38	5.6	05
1.3	1080	0.37	1009	1.0	0.36	978	B			B-C	B-C			37	5.6	06
1.1	1290	0.25	770	1.3	0.32	978	B			B-C	B-C			35	5.6	07
0.8	1800	0.25	921	1.1	0.27	978	B			B-C	B-C			30	5.6	08
0.7	2040	0.18	751	1.3	0.23	978	B			B-C	B-C			30	5.6	09
0.6	2400	0.18	825	1.2	0.21	978	B			B-C	B-C			28	5.6	10
0.5	3000	0.18	958	1.0	0.18	978	B			B-C	B-C			26	5.6	11

Motor Flanges Available
Flange Motore Disponibili

Supplied with Reduction Bushing
Fornito con Bussola di Riduzione

Available on Request without reduction bushing
Disponibile a Richiesta senza Bussola di Riduzione

Motor Flange Holes Position
Posizione Fori Flangia Motore

EN Unit 115 is supplied without lubricant and equipped with a breather, level and drain plugs. User can add mineral oil keeping existing plugs. Should the user wish to fill it with synthetic oil, it is recommended to replace the existing plugs with a type that are closed. Gearbox 050 is supplied lubricated for life. See tab.1 for oils and recommended quantity. In tab.2 there are radial loads and axial loads applicable to the gearbox.

I Il riduttore tipo 115 è fornito di lubrificazione con tappi di sfiato, livello e scarico olio. L'utente può immettere olio minerale mantenendo i tappi esistenti. Se immetterà olio sintetico, dovrà sostituire i tappi esistenti con altri tipo chiuso. Il riduttore 050 è fornito lubrificato a vita con olio sintetico. Tab.1 per oli e quantità consigliati. Tab.2 carichi radiali e assiali applicabili al riduttore.

D Das Getriebe der Baugröße 115 wird ohne Schmiermittel geliefert. Es ist jedoch mit Einfüllschraube, Überdruckventil und Ablassschraube ausgerüstet. Das benötigte mineralische Öl kann über die Einfüllschraube eingefüllt werden. Sollte synthetisches Öl bevorzugt werden, so ist sind das eingebaute Überdruckventil durch eine geschlossenen Schraube zu ersetzen. Das Getriebe der Baugröße 050 ist lebensdauer geschmiert. In Tabelle 1 ist die Schmiermenge und das empfohlene Schmiermittel angegeben. In Tabelle 2 sind die zulässigen Radial - und Axialbelastungen des Getriebes aufgeführt.

F Le réducteur de type 115 est fourni sans lubrification et avec un bouchon de remplissage, de niveau et d'évacuation de l'huile. L'utilisateur peut y verser de l'huile minérale en conservant les bouchons existants. S'il y versera de l'huile synthétique, il devra substituer les bouchons existants avec d'autres bouchons de type fermé. Le réducteur de type 050 est fourni lubrifié à vie avec de l'huile synthétique. Voir tableau 1 concernant les huiles et les quantités conseillées. Voir tableau 2 concernant les charges radiales et axiales applicables au réducteur.

E El reductor tamaño 115 se suministra sin lubricante, provisto de tapones de respiración, nivel y descarga de aceite. El usuario puede utilizar aceite mineral, manteniendo los tapones existentes. Si prefiere utilizar aceite sintético deberá sustituir los tapones existentes por tapones ciegos. El reductor 050 se suministra lubricado de por vida con aceite sintético. Ver tabla 1, para cantidades y aceites recomendados. En la tabla 2, se encuentran las cargas radiales y axiales admitidas por el reductor.

B3	B6	B7	B8	V5	V6
2.0/0.14 LT	1.35/0.14 LT	1.35/0.14 LT	2.0/0.14 LT	2.0/0.14 LT	2.0/0.14 LT

AGIP Blasia 460

For all details on lubrication and plugs check our website [Per maggiori dettagli su lubrificazione e tappi olio vedi il nostro sito web](#) **tab. 1**

RADIAL AND AXIAL LOADS

Output shaft

Albero di uscita

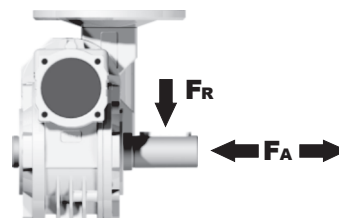

n_2 [min ⁻¹]	FA [N]	FR [N]
25	1200	6000
15	1400	7000

Input shaft

albero in entrata

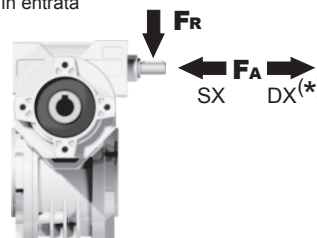

n_1 [min ⁻¹]	FA [N]	FR [N]
1400	76	380

*Strong axial loads in the DX direction are not allowed.
Non sono consentiti forti carichi assiali con direzione DX

tab. 2

3D dimensions on request

P115FB... Basic wormbox
Riduttore base

M. flanges	Kit code	øF	A
63B5	K050.4.041	138	78.5
71B5	K050.4.042	160	76
80B5	K050.4.043	200	76.5
56B14	KC40.4.049	80	76
63B14	K050.4.047	90	78.5
71B14	K050.4.045	105	76
80B14	K050.4.046	120	76.5

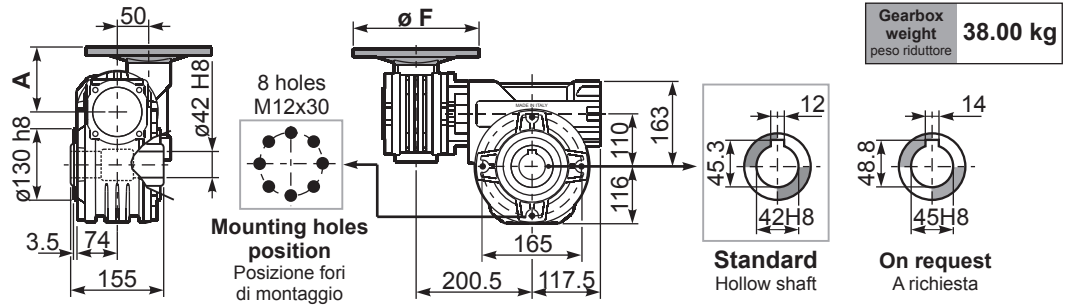

P115PA... Feet
Piedini

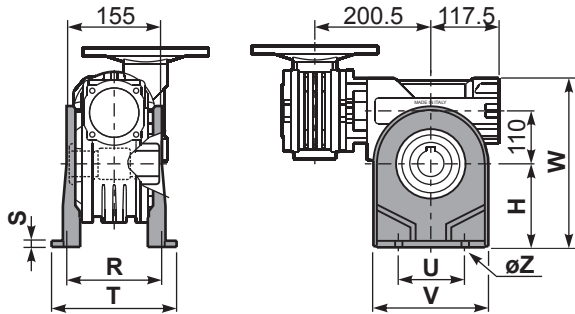

	H	R	S	T	U	V	Y	W	øZ	kit code
type B	170	180	22	224	200	240	286	333	ø13	K110.9.022
type S	172	160	8	204	200	240	288	335	ø14	KS110.9.023

P115PB... Feet
Piedini

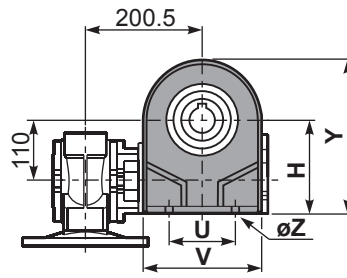

P115PV... Feet
Piedini

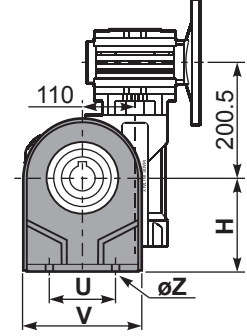

P115FC... Output flange
Flangia uscita

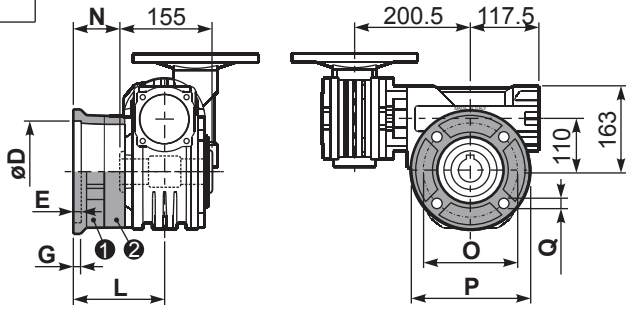

type B	øD	E	G	L	N	O	P	Q	kit code
FC	170 ^{+0.083} / _{+0.043}	11	16.5	131.5	54	230	270	13	1. K110.9.010 2. -
FL	170 ^{+0.083} / _{+0.043}	11	16.5	179.5	102	230	270	13	1. K110.9.011 2. -
type S	øD	E	G	L	N	O	P	Q	kit code
F1	180 ^{+0.040} / ₀	5	18	150	72.5	215	250	15	1. KS110.9.014 2. -
F2	170 ^{+0.083} / _{+0.043}	9.5	15	178	100.5	230	270	13	1. KS110.9.012 2. -
F3	180 ^{+0.040} / ₀	5	18	130	52.5	215	250	15	1. KS110.9.013 2. -

P115BR... Reaction arm
Braccio di reazione

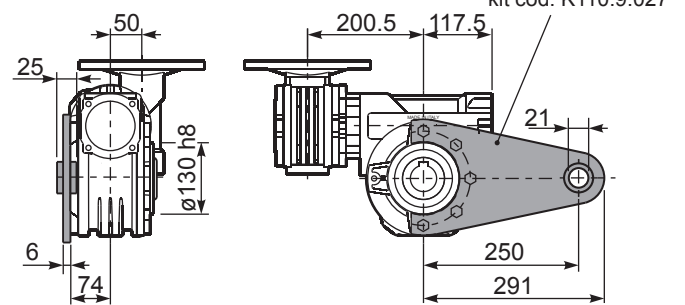

P115....S... Single Shaft
Albero lento semplice

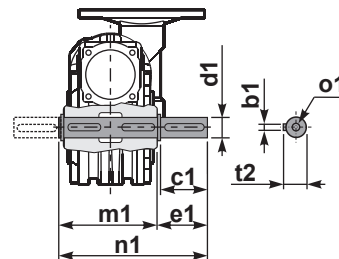

P115....D... Double Shaft
Albero lento bisp.

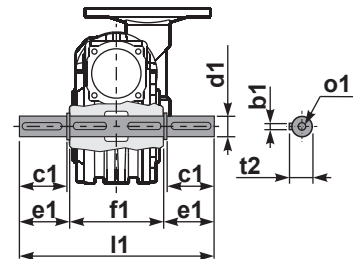

1 kit cod. K110.5.028 type B

2 kit cod. K110.5.029 type B

R115FB... Input shaft
Albero in entrata

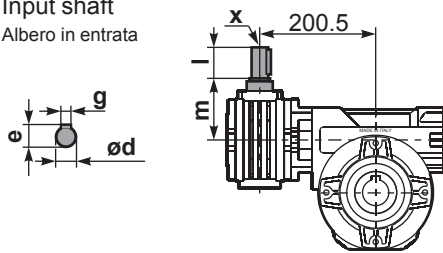

	ød	e	g	l	m	x	kit code
type B	16 h6	18	5	30	74.5	M6x16	1. K050.5.006 PAM71 2. K050.5.007 PAM80
type S	14 h6	16	5	30	74.5	M5x10	1. KS050.5.008 PAM71 2. KS050.5.009 PAM80

	b1	c1	d1	e1	f1	l1	m1	n1	t2	o1
type B	12	75	42 ^{-0.005} / _{-0.020}	96.5	155	348	163.5	260	45	M12x32
type S	-	-	-	-	-	-	-	-	-	-